

**SUPER  
SILENCED**

Soundproof box



Easy installation



Compact

The engine is cooled by a coolant loop in a closed circuit. The system consists of a heat exchanger, inside which the heat exchange between coolant and sea water takes place. Two separate pumps provide for the circulation of coolant and seawater. Air flows ensure effective cooling of the alternator.

The excellent accessibility makes maintenance operations easier, even with the generator installed in confined environments.



# GS 52 MTS - 60 MTS STANDARD EQUIPMENT

## Control panel

- \_ CBU EVO IL4 device controls and drives the genset. The large display and control pushbuttons allow easy use and monitoring:
  - Manual start
  - Voltage Vac
  - Frequency Hz
  - Hour meter
  - Genset battery voltage
  - Oil low pressure alarm
  - Engine preheating
  - Engine high temperature alarm
  - Alternator battery charger failure alarm
  - Protection alarm for frequency and rpm
  - Alarm history
  - Maintenance warnings
  - General alarm outlet
  - RUN outlet
  - Ready outlet
  - Programmable AUX outlet
- \_ Emergency stop button
- \_ Magneto-thermal protection

## Engine

- \_ Easy maintenance access to the feeding and lubrication systems, the sea water pump and the air filter
- \_ Double vibration dumping system
- \_ Oil drain pump

## Soundproof cabin

- \_ Made of extremely light marine aluminum with very high resistance to external agents

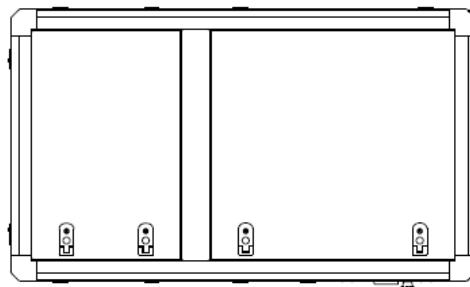
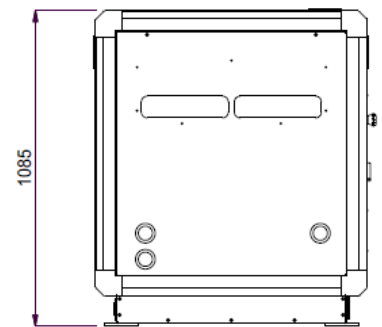
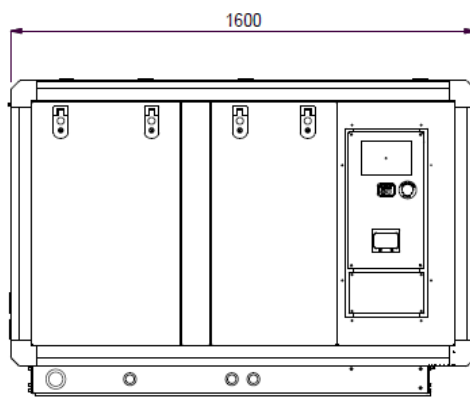
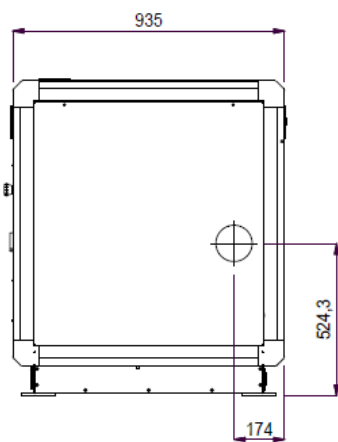

50 Hz

60 Hz

AC alternator -	Synchronous, 4 poles, with AVR	
Cooling	Air	
Voltage	400 V	480 V
Frequency	50 Hz	60 Hz
Amps	75.1 A	72.3 A
Max power	52 kVA	60 kVA
Continuous power	48 kVA	50 kVA
Power Factor	cos $\phi$ 0.8	
Insulating class	H	
Voltage stability	$\pm 2\%$	
Frequency stability	$\pm 5\%$	

The power is referred to an atmospheric pressure of 100 kPa, a humidity percentage of 30% and an ambient temperature of 25°C.

Model	Perkins 1103A-33TG1	
Type	Diesel	
Cylinder block material	nr 3	
Cylinders	Cast iron	
Bore	105 mm - 4.14 in	
Stroke	127 mm - 5 in	
Displacement	3300 cc - 201.38 CID	
Power	61.2 hp - 45.02 kWm	72.3 hp - 53.18 kWm
RPM	1500	1800
Compression ratio	17.3:1	
Engine head material	Direct injection	
Combustion system	Cast iron	
Speed governor	Electronic	
Lubrication system	Forced	
Oil sump capacity with filter	6.5 l - 1.83 gl	
Engine stop system	Solenoid valve	
Fuel pump	Electric	
Max. fuel pump head	700 mm - 27.5 in	
Fuel consumption	10.7 l/h - 2.83 gl/h	12.9 l/h - 3.41 gl/h
Air intake		
Starting battery	80 Ah - 12 V	
Battery charger	40 Ah - 12 V	
Starter motor	12 kW - 12 V	
Max. inclination	25°	
Water pump flow	86 l/min - 22.71 gl/min	
Sea water inlet pipe $\emptyset$	25 mm - 1"	
Exhaust pipe $\emptyset$	102 mm - 4"	
Input/Output fuel pipe $\emptyset$	8 mm - 5/16"	

Dimensions (L x W x H)	1600 x 935 x 1085 mm - 63 x 36.8 x 42.7 in (with soundproof box)	
Weight	940 Kg - 2073 lb (with soundproof box)	
Noise Level	58 dBA at 7 mt (23 ft)	59 dBA at 7 mt (23 ft)



	Accessory	Code
Accessories on request	• Filtering kit: sea water inlet, sea water strainer, taps, fittings D.25 - ref.4	03793
	• Mase exhaust kit: sea water lock, silencer, outlet D.90 Vetus	038325
	• Siphon break D.25 - ref.3	015849
	• Vetus LP90 muffler	71688
	• Vetus MP90 silencer	71690
	• Centek muffler 3" 1/2	71689
	• Centek water/gas separator 3" 1/2	71692
	• Remote START/STOP panel with 20m cable for Comap IL4 - ref.1	037561
	• Comap IL4 remote start panel with 20m cable - ref.2	039607
	• Cruise Kit	913947

