



Compact



Minimal maintenance



Ultra bright LED lights

Super silenced, compact and lightweight standalone lighting tower. Equipped with Yanmar 3000 RPM or Kubota 1500 RPM engine and hydraulic lifting system easily manageable via a convenient selector located on the instrument panel. Ultra-bright LED lights, supplied with site tow trailer for a easy handling or supplied on base.



LT 5000 SS-Y SS-K STANDARD EQUIPMENT



LT 5000 SS-Y

8 mt lighting tower (340° rotation) with hydraulic lifting
 Auto engine protection shutdown system in case of: low oil pressure, battery charger failure;
 Starting battery
 Emergency stop button
 Hourmeter
 Fuel level gauge
 230V - 16A single-phase socket
 Power output protections
 Earth leakage circuit breaker (ELCB)
 Lamps switch
 Up/down tower switch
 5 stabilizers
 GRT2W: 2 wheels site trailer - max. speed: 10 km/h
 Lifting hooks (on the base)
 Fork-lift pockets

LT 5000 SS-K

8 mt lighting tower (340° rotation) with hydraulic lifting
 Controller with digital display for full monitoring of the unit parameters, with auto engine protection shutdown system in case of: emergency stop, low oil pressure, low fuel level, high coolant temperature
 Starting battery
 Emergency stop button
 Hourmeter
 Fuel level gauge
 230V - 16A single-phase socket
 Power output protections
 Earth leakage circuit breaker (ELCB)
 Lamps switch
 Up/down tower switch
 Auto/manual switch
 5 stabilizers
 GRT2W: 2 wheels site trailer - max. speed: 10 km/h
 Lifting hooks (on the base)
 Fork-lift pockets

DIMENSIONS IN MM

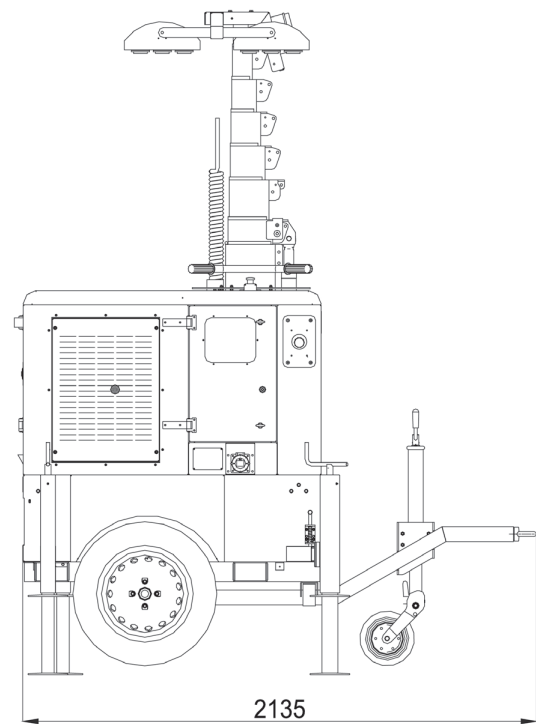
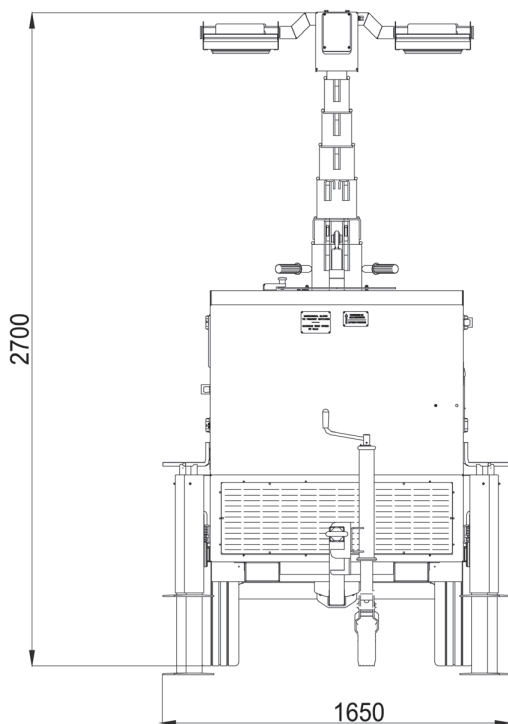

	LT 5000 SS-Y	LT 5000 SS-K
Noise level Lwa	92 (67 dB a 7 mt)	82 (57 dB a 7 mt)
AC generator-50Hz Single-phase max. power Power Factor	4,2 kVA - 230 V	3,5 kVA - 230 V
	Synchronous cos φ 0,8	
Engine Fuel No. cylinders Power Displacement Cooling system Starting system Fuel tank capacity Fuel consumption @75%	Yanmar L 70 V 3000 RPM Stage V* Diesel 1 6 hp (4,5 kWm) 320 cm ³ Air Electric 100 lt 1 lt/h	Kubota Z482 1500 RPM Diesel 2 4,8 hp (3,6 kWm) 479 cm ³ Water Electric 100 lt 0,85 lt/h
Insulation Class Ambient temperature Altitude Degree of protection Dimensions (LxWxH) Max. dimensions (LxWxH)	H 40 °C 1000 mt IP 23 2135x1650x2700 mm 2135x2750x9250 mm	
Dry weight	750 kg (manual lifting version) 860 kg (hydraulic lifting version)	800 kg (manual lifting version) 895 kg (hydraulic lifting version)



Compliant with Regulation (EU) 2016/1628 on emissions for mobile machinery.

*Stage V



LT 5000 SS-Y SS-K

Options on request

- 1- Manual lifting system
- 2- Floodlight with 4 x 180 W / 4 x 320 W LED lamps
- 3- Dusk sensor



NOTE

