



Compact



Minimal maintenance



Ultra bright LED lights

Compact and lightweight standalone lighting tower, equipped with Kubota 1500 RPM engine. Ultra-bright LED lights, supplied with site tow trailer for a easy handling or supplied on base.



# LT 10000 K

# STANDARD EQUIPMENT



## LT 10000 K

8 mt lighting tower (340° rotation) with manual lifting  
Auto engine protection shutdown system in case of: low oil pressure, battery charger failure;  
Starting battery  
Emergency stop button  
Hourmeter  
Fuel level gauge  
230V - 16A single-phase socket  
Power output protections  
Earth leakage circuit breaker (ELCB)  
Lamps switch  
3 stabilizers  
GRT2W: 2 wheels site trailer - max. speed: 10 km/h  
Lifting hooks  
Fork-lift pockets

## DIMENSIONS IN MM

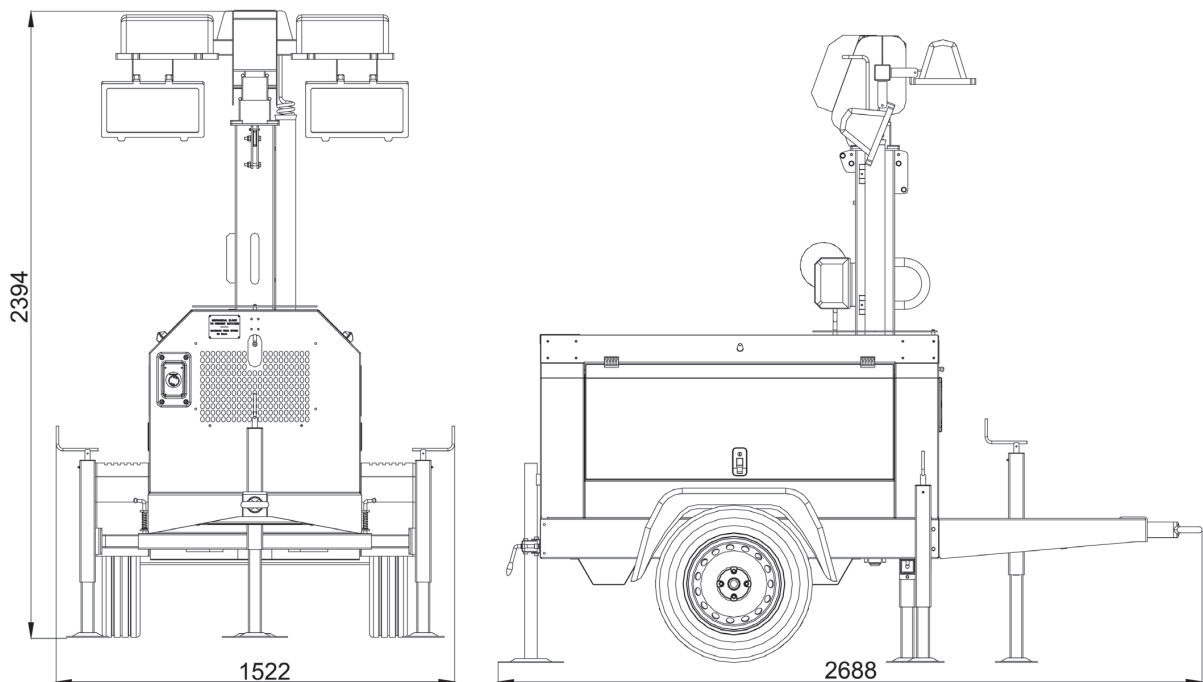

LT 10000 K	
Noise level Lwa	97 (72 dB a 7 mt)
AC generator-50Hz	Synchronous
Single-phase max. power	9 kVA - 230 V
Power Factor	cos $\phi$ 0,8
Kubota 1500 RPM engine	D 1105
Fuel	Diesel
No. cylinders	3
Power	12,7 hp (9,5 kWm)
Displacement	1123 cm <sup>3</sup>
Cooling system	Water
Starting system	Electric
Fuel tank capacity	100 lt
Fuel consumption @75%	2 lt/h
Insulation Class	H
Ambient temperature	40 °C
Altitude	1000 mt
Degree of protection	IP 23
Dimensions (LxWxH)	2688x1522x2394 mm
Max. dimensions (LxWxH)	2688x2614x8950 mm
Dry weight	670 kg



## LT 10000 K

Options on request

- 1- Hydraulic lifting system
- 2- Floodlight with 4 x 180 W / 4 x 320 W LED lamps

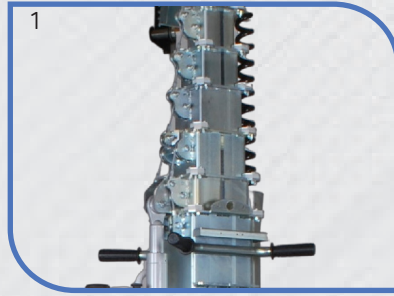

### NOTE

---

---

---

---

---

---

