



**SUPER
SILENCED**

Soundproof box



Easy installation



Compact

The engine revs vary depending on the required load; therefore, if you have only few electrical applications connected, the genset will automatically calibrate to the required power, while ensuring exceptional voltage and frequency stability. That means lower fuel consumption, reduction of emissions, lower need of maintenance and more silent operation. Extremely compact and quiet, the genset is equipped with a double shock absorbing system to increase comfort: the first one absorbs vibrations from engine-alternator to the frame, the second one absorbs residual micro-vibrations from frame to vessel.



GVi 6500 - 6600

STANDARD EQUIPMENT

Control panel

_ CBU EVO IL4 device controls and drives the genset. The large display and control pushbuttons allow easy use and monitoring:

- Manual start
- Voltage Vac
- Frequency Hz
- Engine rpm
- Hour meter
- Genset battery voltage
- Oil low pressure alarm
- Engine preheating
- Engine high temperature alarm
- Alarm history
- Maintenance warnings

- _ Emergency stop button
- _ Magneto-thermal protection

Engine

_ Easy maintenance access to the feeding and lubrication systems, the sea/water pump and the air filter

_ Double vibration dumping system

_ Oil drain pump

Soundproof cabin

_ Made of extremely light marine aluminum with very high resistance to external agents

Insulated poles kit (for metal hull boats), dry exhaust kit and keel cooling kit are available on request

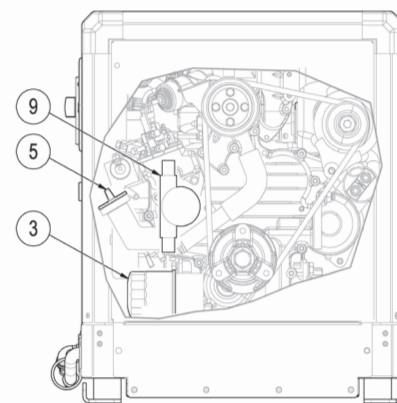
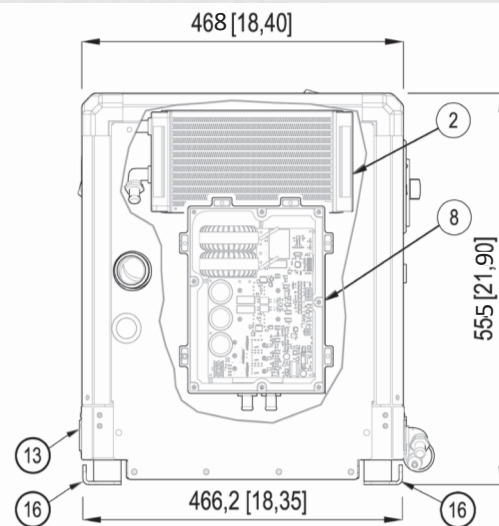
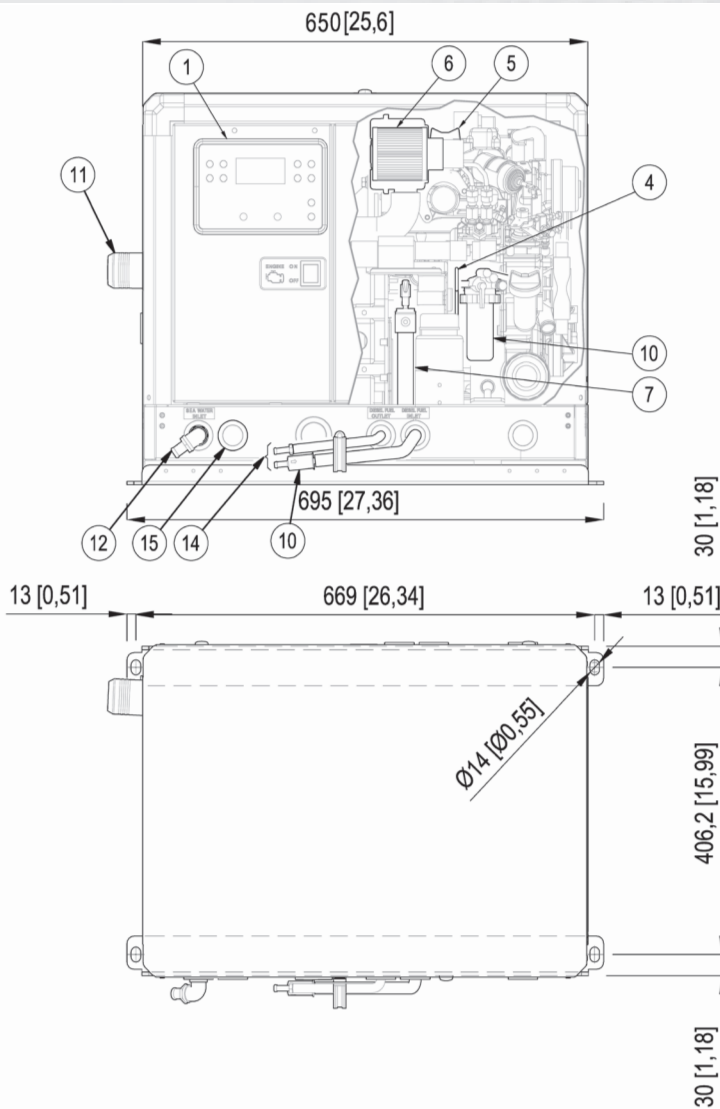

- | | | | |
|--------------------------|---------------------|--------------------------------|------------------------------------|
| 1. Control panel | 6. Air filter | 11. Exhaust manifold (d.50 mm) | 14. Fuel tank connections (d.8 mm) |
| 2. Air / water exchanger | 7. Oil drump pump | 12. Sea water intake (d.16 mm) | 15. Cables outlet |
| 3. Oil filter cartridge | 8. Fresh water pump | 13. Battery connections | 16. Genset fixing brackets |
| 4. Oil dipstick | 9. Sea water pump | | |
| 5. Engine oil filler | 10. Fuel filter | | |



50 Hz

60 Hz



AC alternator Cooling Voltage Frequency Amps Max. Power Power Factor Insulating class Voltage stability Frequency stability	Permanent magnets (PMG)	
	Air/Water (Intercooler W/A)	
	230 to 240	115 to 240
	50/60 Hz	
	28.3 to 27.1 A	56.5 to 27.1 A
	6.5 kW	
	cos ϕ 1	
	H	
	$\pm 1\%$	
	$\pm 1\%$	

The power is referred to a sea water temperature up to 31°, an atmospheric pressure of 100 KPa and a humidity percentage of 30%

Model	KUBOTA Z482
Type	Diesel 4 stroke
Cylinders	nr 2
Cylinder block material	Cast iron
Bore	67 mm - 2.64 in
Stroke	68 mm - 2.68 in
Displacement	479 cc - 29.23 CID
Power	11.5 hp - 8.46 kWm (at 3150 RPM)
RPM	2150 - 3150
Compression ratio	23.5:1
Combustion system	Indirect injection
Engine head material	Cast Iron
Speed governor	Electronic with actuator
Lubrication system	Forced
Oil sump capacity with filter	1.7 l - 0.48 gl
Engine stop system	Electromagnet
Fuel pump	Electric
Max. fuel pump head	700 mm - 27.5 in
Fuel consumption	2.6 l/h - 0.69 gl/h
Starting battery	55 Ah - 12 V
Battery charger	30 Ah - 12 V
Starter motor	0.8 kW - 12 V
Max. inclination	25°
Water pump flow	22 l/min - 5.8 gl/min
Sea water inlet pipe \varnothing	16 mm - 5/8"
Exhaust pipe \varnothing	50 mm - 2"
Input/Output fuel pipe \varnothing	8 mm - 5/16"

Dimensions (L x W x H)	650 x 468 x 555 mm - 25.6 x 18.4 x 21.9 in (with soundproof box)
Weight	155 Kg - 342 lb49 dBA at 7mt (23 ft)
Noise Level	54 dBA at 7 mt (23 ft)



Accessory

Code

Accessories on request

• Installation kit D.50: filtering set, exhaust set and siphon break D.16	012276
• Filtering kit: sea water inlet, sea water strainer, taps, fittings D.16 - ref.5	04349
• Mase exhaust kit: sea water lock, silencer, outlet D.50 - ref.3	04658
• Mase super silenced exhaust kit & exhaust gas separator D.50 - ref.6	010078
• Siphon break D.16 - ref.4	04290
• Mase Muffler D.50	70795
• Silencer Mase D.50	71809
• Mase water/gas exhaust separator D.50	04488
• Vetus LP50 muffler	71148
• Vetus silencer MP50	71751
• Silencer Vetus c.71751 with soundproofing sponge	039866
• Vetus Separator LGS5038	71717
• Centek muffler 2"	71155
• Centek 2" water/gas exhaust separator	71156
• Water protection	040538
• Parallel cable	036625
• Soundproofing cabin	038413
• Remote control panel START/STOP with 20 mt cable for Comap IL4 - ref.1	037698
• Remote control panel for Comap IL4 with 20mt cable - ref.2	039608
• Cruise KIT	913651

