



**SUPER  
SILENCED**

Soundproof box



Easy installation



Compact

The intercooler W/A assures the perfect functioning of the generator independently of the external ambient temperature, therefore the alternator and the engine will work at ideal temperature optimizing the performance and reliability of the gen-set.

The generator may be installed in any room on the vessel without the need of ventilation blowers.

Extremely compact and quiet, the generator is equipped with a double shock absorbing system to increase comfort: the first one absorbs vibrations from engine-alternator to the frame, the second one absorbs residual micro-vibrations from frame to vessel.



## Control panel

\_ The CBU module is equipped with a large display and includes multiple functions for the complete monitoring of the generator:

- Manual start
  - Voltage Vac
  - Frequency Hz
  - Engine rpm
  - Hour meter
  - Genset battery voltage
  - Oil low pressure alarm
  - Engine high temperature alarm
  - Alternator high temperature alarm
  - Alarm history
  - Maintenance warnings and 10 meters connection cable
- \_ Emergency stop button
- \_ Magneto-thermal protection

## Engine

- \_ Easy maintenance access to the feeding and lubrication systems, the sea/water pump and the air filter
- \_ Double vibration dumping system
- \_ Oil drain pump

## Soundproof cabin

- \_ Made of extremely light marine aluminum with very high resistance to external agents

Insulated poles kit (for metal hull boats), dry exhaust kit and keel cooling kit are available on request

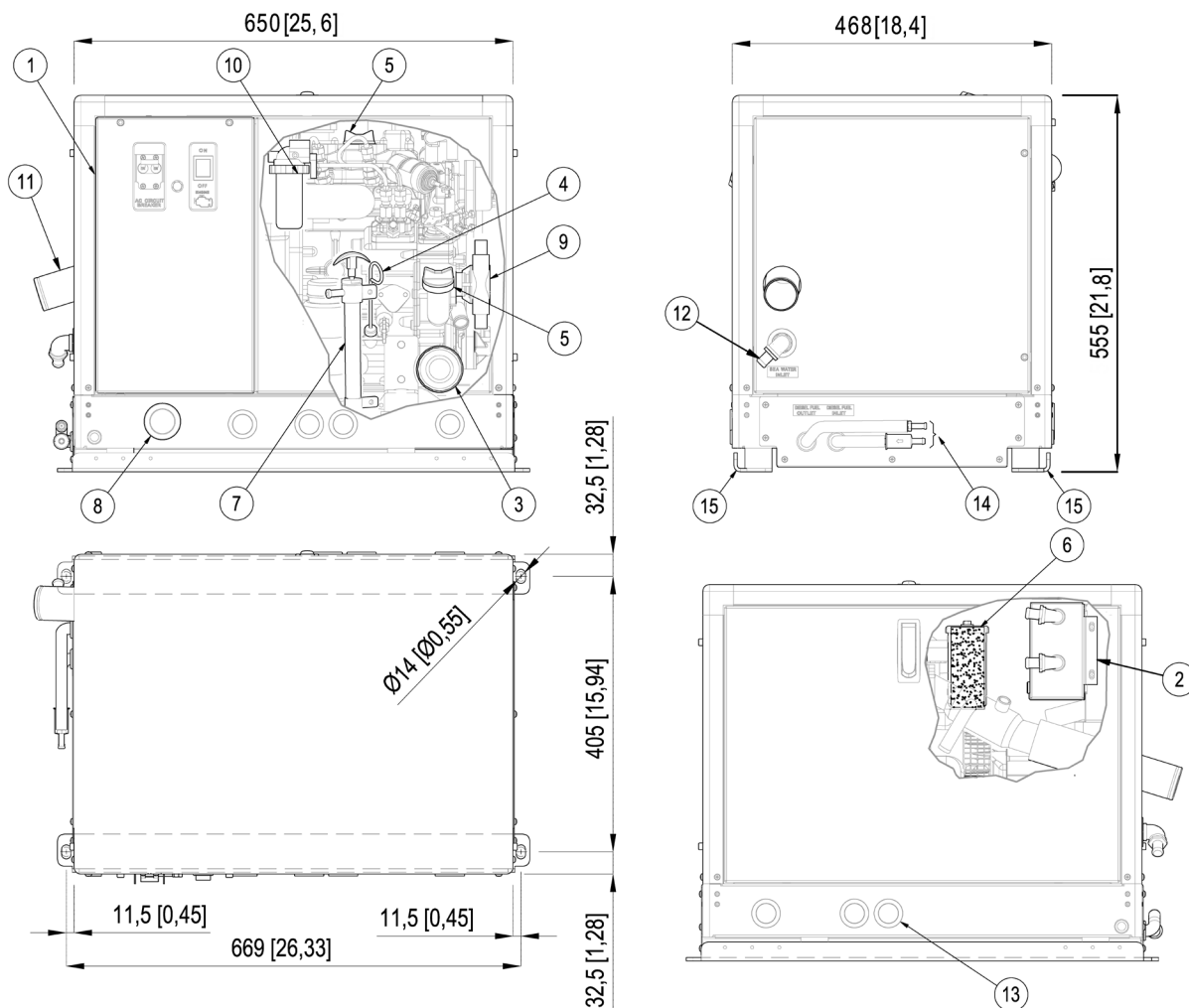

- |                          |                   |                                |                                    |
|--------------------------|-------------------|--------------------------------|------------------------------------|
| 1. Control panel         | 6. Air filter     | 11. Exhaust manifold (d.50 mm) | 14. Fuel tank connections (d.8 mm) |
| 2. Air / water exchanger | 7. Oil drump pump | 12. Sea water intake (d.16 mm) | 15. Genset fixing brackets         |
| 3. Oil filter cartridge  | 8. Cables outlet  | 13. Battery connections        |                                    |
| 4. Oil dipstick          | 9. Sea water pump |                                |                                    |
| 5. Engine oil filler     | 10. Fuel filter   |                                |                                    |



## 50 Hz

## 60 Hz

AC alternator	Synchronous, 2 poles, brushless , self-energized, self regulated	
Cooling	Air/Water (Intercooler W/A)	
Voltage	115 or 230 V	120 or 240 V
Frequency	50 Hz	60 Hz
Amps	53 or 26.5 A	59.2 or 29.6 A
Max. Power	6.1 kW	7.1 kW
Continuous power	5.6 kW	6.6 kW
Power Factor	cos $\phi$ 1	
Insulating class	H	
Voltage stability	$\pm 10\%$	
Frequency stability	$\pm 5\%$	

The power is referred to a sea water temperature up to 31°, an atmospheric pressure of 100 KPa and a humidity percentage of 30%

Model	Kubota Z482	
Type	Diesel 4 stroke	
Cylinders	nr 2	
Cylinder block material	Cast iron	
Bore	67 mm - 2.64 in	
Stroke	68 mm - 2.68 in	
Displacement	479 cc - 29.23 CID	
Power	11.5 - 8.46 hp-kWm	13.3 - 9.78 hp-kWm
RPM	3000	3600
Compression ratio	23.5:1	
Combustion system	Indirect injection	
Engine head material	Cast iron	
Speed governor	Centrifugal mechanical	
Lubrication system	Forced	
Oil sump capacity with filter	1.7 l - 0.48 gl	
Engine stop system	Electromagnet	
Fuel pump	Electric	
Max. fuel pump head	700 cm - 27.5 ft	
Fuel consumption	2.6 l/h - 0.69 gl/h	2.7 l/h - 0.71 gl/h
Starting battery	55 Ah - 12 V	
Battery charger	14 Ah - 12 V	
Starter motor	0.8 kW - 12 V	
Max. inclination	25°	
Water pump flow	20 l/min - 5.28 gl/min	
Sea water inlet pipe $\emptyset$	16 mm - 5/8"	
Exhaust pipe $\emptyset$	50 mm - 2"	
Input/Output fuel pipe $\emptyset$	8 mm - 5/16"	

Dimensions (L x W x H)	650 x 468 x 555 mm - 25.6 x 18.4 x 21.8 in (with soundproof box)	
Weight	165 Kg - 364 lb (with soundproof box)	
Noise Level	54 dBA at 7 mt (23 ft)	56 dBA at 7 mt (23 ft)



Accessory	Code
• Installation kit D.50: filtering set, exhaust set and siphon break D.16	012276
• Filtering kit: sea water inlet, sea water strainer, taps, fittings D.16 - ref.3	04349
• Exhaust kit: muffler, silencer, exhaust outlet D.50 MASE - ref.1	04658
• Super silenced exhaust kit & exhaust gas separator D.50 MASE - ref.4	010078
• Siphon break D.16 - ref.2	04290
• Mase Muffler D.50	70795
• Silencer Mase D.50	71809
• Mase water/gas exhaust separator D.50	04488
• Vetus LP50 muffler	71148
• Vetus silencer MP50	71751
• Silencer c.71751 with soundproofing sponge	039866
• Vetus Separator LGS5038	71717
• Centek muffler 2"	71155
• Centek 2" water/gas exhaust separator	71156
• Water protection - ref.5	040538
• Soudproofing cabin	038413
• Remote START/STOP 20-meter control kit for CBU (3000 RPM)	041238
• Cruise KIT	913840

Accessories on request

