



**SUPER  
SILENCED**

Soundproof box



Easy installation



Compact

The intercooler W/A assures the perfect functioning of the generator independently from the external environment temperature, therefore the alternator and the engine will work at ideal temperature optimizing the performance and reliability of the genset.

The generator may be installed in any room on the vessel without the need of ventilation blowers.

Extremely compact and quiet, the generator is equipped with a double shock absorbing system to increase comfort: the first one absorbs vibrations from engine-alternator to the frame, the second one absorbs residual micro-vibrations from frame to vessel.



# GSi 22 K - 24.6 K

# STANDARD EQUIPMENT

## Control panel

\_ CBU EVO IL4 device controls and drives the genset. The large display and control pushbuttons allow easy use and monitoring:

- Manual start
- Voltage Vac
- Frequency Hz
- Hour meter
- Genset battery voltage
- Oil low pressure alarm
- Engine preheating
- Engine high temperature alarm
- Alternator battery charger failure alarm
- Protection alarm for frequency and rpm
- Alarm history
- Maintenance warnings
- General alarm outlet
- RUN outlet
- Ready outlet
- Programmable AUX outlet

- \_ Emergency stop button
- \_ Magneto-thermal protection

## Engine

\_ Easy maintenance access to the feeding and lubrication systems, the sea/water pump and the air filter

\_ Double vibration dumping system

\_ Oil drain pump

## Soundproof cabin

\_ Made of extremely light marine aluminum with very high resistance to external agents

Insulated poles kit (for metal hull boats), dry exhaust kit and keel cooling kit are available on request

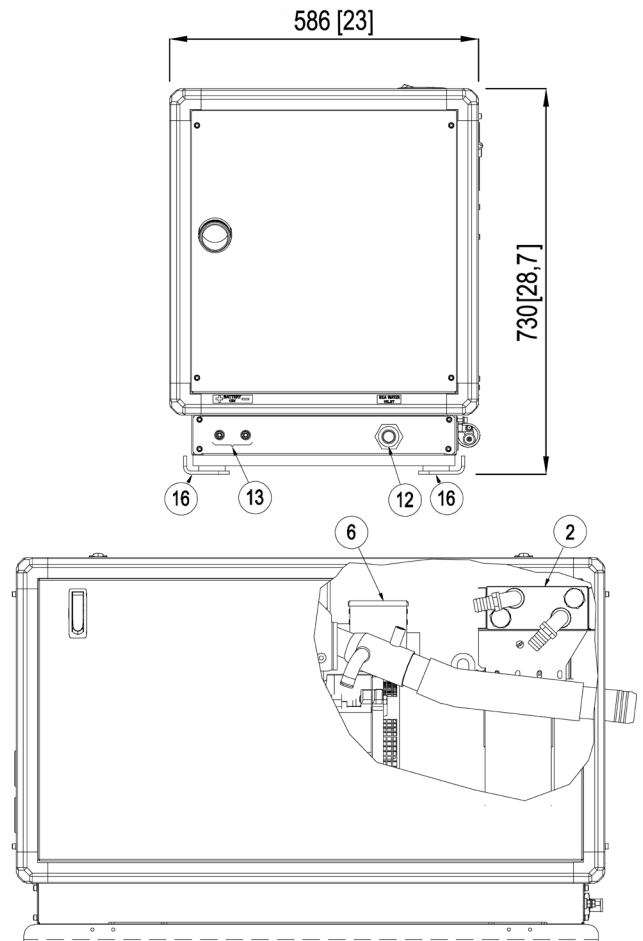
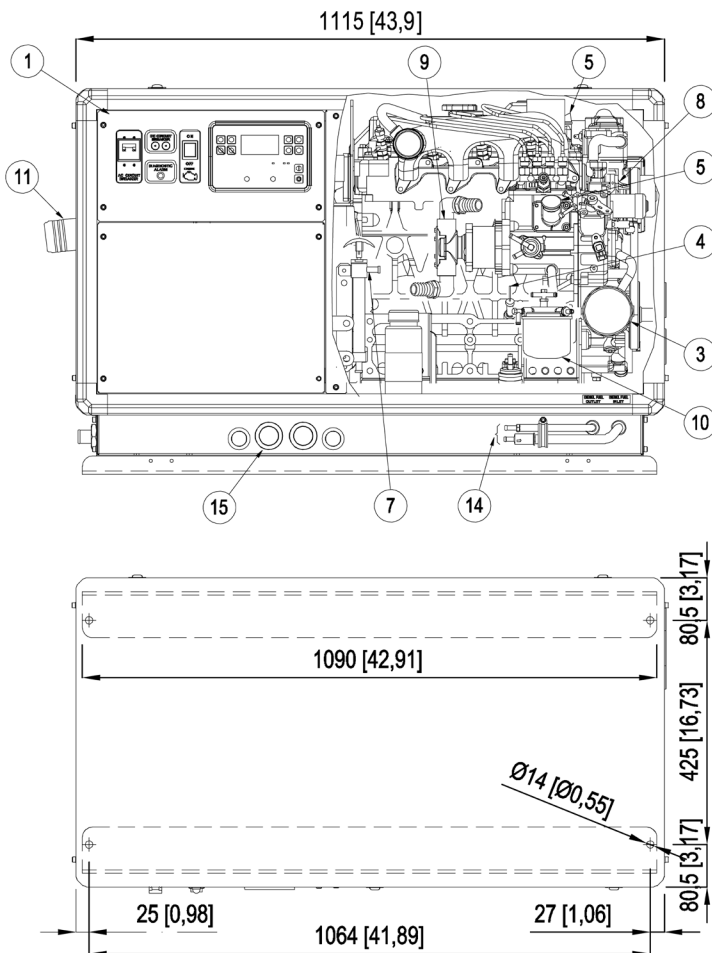

- |                          |                     |                                |                                    |
|--------------------------|---------------------|--------------------------------|------------------------------------|
| 1. Control panel         | 6. Air filter       | 11. Exhaust manifold (d.60 mm) | 14. Fuel tank connections (d.8 mm) |
| 2. Air / water exchanger | 7. Oil drump pump   | 12. Sea water intake (d.25 mm) | 15. Cables outlet                  |
| 3. Oil filter cartridge  | 8. Fresh water pump | 13. Battery connections        | 16. Genset fixing brackets         |
| 4. Oil dipstick          | 9. Sea water pump   |                                |                                    |
| 5. Engine oil filler     | 10. Fuel filter     |                                |                                    |



50 Hz

60 Hz



AC alternator	Synchronous, 4 poles, brushless, self-energized, with automatic voltage regulator (AVR)	
Cooling	Air/Water (Intercooler W/A)	
Voltage	115 or 230 V	120 or 240 V
Frequency	50 Hz	60 Hz
Amps	191 or 95.7 A	200 or 100 A
Max. Power	22 kW	24 kW
Continuous power	20 kW	22 kW
Power Factor	cos $\phi$ 1	
Insulating class	H	
Voltage stability	$\pm 2\%$	
Frequency stability	$\pm 2\%$	

The power is referred to a sea water temperature up to 31°, an atmospheric pressure of 100 KPa and a humidity percentage of 30%

Model	KUBOTA V2403	
Type	Diesel 4 stroke	
Cylinders	nr 4	
Cylinder block material	Cast iron	
Bore	87 mm - 3.43 in	
Stroke	102 mm - 4.03 in	
Displacement	2434 cc - 148.53 CID	
Power	29.5 hp - 21.70 kWm (at 1500 RPM)	35.5 hp - 26.11 kWm (at 1800 RPM)
RPM	1500	1800
Compression ratio	23.2:1	
Combustion system	Indirect injection	
Engine head material	Cast iron	
Speed governor	Electronic	
Lubrication system	Forced	
Oil sump capacity with filter	6.6 l - 1.86 gl	
Engine stop system	Electromagnet	
Fuel pump	Electric	
Max. fuel pump head	700 mm - 27.5 in	
Fuel consumption	6.1 l/h - 1.61 gl/h	6.5 l/h - 1.72 gl/h
Starting battery	100 Ah - 12 V	
Battery charger	40 Ah - 12 V	
Starter motor	2 kW - 12 V	
Max. inclination	25°	
Water pump flow	28 l/min - 7.39 gl/min	
Sea water inlet pipe $\emptyset$	25 mm - 1"	
Exhaust pipe $\emptyset$	60 mm - 2" 1/2	
Input/Output fuel pipe $\emptyset$	8 mm - 5/16"	

Dimensions (L x W x H)	1115 x 585 x 730 mm - 43.9 x 23 x 28.7 in (with soundproof box)	
Weight	475 Kg - 1047 lb (with soundproof box)	
Noise Level	47 dBA a 7 mt (23 ft)	50 dBA a 7 mt (23 ft)



## Accessory

## Code

Accessories on request

• Filtering kit: sea water inlet, sea water strainer, taps, fittings D.25 - ref.4	03793
• Siphon break D.25 - ref.3	015849
• Vetus LP60 muffler	71711
• Vetus silencer MP60	71746
• Silencer c.71746 with soundproofing sponge	039865
• Vetus Separator LGS6050	71712
• Centek muffler 2" 1/2 - ref.5	71714
• Centek 2" 1/2 water/gas exhaust separator - ref.6	71713
• Remote START/STOP panel with 20m cable for Comap IL4 - ref.1	037698
• Comap IL4 remote start panel with 20-meter cable - ref.2	039608
• Oil water senders kit IS Kubota	039678
• Cruise KIT	913684

